



### CRID.01

#### Product Features

- Aluminum Body
- Mounting Type: Split Shaft
- Weight: 43 kg / 95 lb
- Sense of Rotation: Same as Input
- 2 Years Guarantee
- 10 Years Spare Part Back Up

#### Applications

- Sewer Cleaning Combination Vehicle
- Vacuum Truck
- Fire Fighting Truck
- Water Jetting Truck
- Sweeping Truck



### CRID.02

#### Product Features

- Aluminum Body
- Mounting Type: Split Shaft
- Weight: 36 kg / 79 lb
- Same as Input
- 2 Years Guarantee
- 10 Years Spare Part Back Up

#### Applications

- Sewer Cleaning Combination Vehicle
- Vacuum Truck
- Fire Fighting Truck
- Water Jetting Truck
- Sweeping Truck



### CRID.16

#### Product Features

- Mounting Type: Split Shaft
- Weight: 33 kg / 73 lb
- Weight: 43 kg / 95 lb
- Sense of Rotation: Same as Input
- 2 Years Guarantee
- 10 Years Spare Part Back Up

#### Applications

- Sewer Cleaning Combination Vehicle
- Vacuum Truck
- Fire Fighting Truck
- Water Jetting Truck
- Sweeping Truck

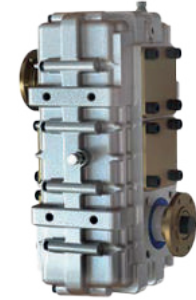

### CRID.28.2

#### Product Features

- Aluminum Body
- Mounting Type: Split Shaft
- Weight: 36 kg / 80 lb
- Sense of Rotation: 1 Output same as Input, second one opposite
- 2 Years Guarantee
- 10 Years Spare Part Back Up

#### Applications

- Sewer Cleaning Combination Vehicle
- Vacuum Truck
- Fire Fighting Truck
- Water Jetting Truck
- Sweeping Truck

TS EN 1028, Iso 9001, Iso 14001, Iso 18001, CE ve Gost-R



celiksanaaracustu @celiksana.co celiksana

www.celiksana.com

Ekrem Demirtaş Caddesi No: 37  
İtob Organize Sanayi Bölgesi, 35868 Menderes / İzmir  
+ 90 232 254 57 27 info@celiksana.com

SINCE 1976



## PTO SERIES

- Sandwich PTO
- Split Shaft PTO
- RPM Increaser/Decreaser



Tech Specification	CRID.01	CRID.02	CRID.16	CRID.28.2
Max. Torque	95 kgm / 931 Nm / 687 LBS-FT	102 kgm / 1000 Nm / 738 lb-ft	156 kgm / 1128 lb-ft	145 kgm / 1421 Nm / 1048 lb-ft
Max. Power	100 kW / 134 HP	130 kW / 174 HP	150 kW / 201 HP	145 kgm / 1421 Nm / 1048 lb-ft
Max. RPM	4000	4000	-	4000
Available Internal Ratios	1/3.25 - 1/1.8 - 1/2.8 - 1/1.4 - 1/2.4 - 1/1.2 - 1/2 - 1/1	1/1 - 1/1.42 - 1/1.66 - 1/2.11 - 1/2.50 - 1/2.73 - 1/3.08	-	1/0.41 - 1/0.79 - 1/0.89 - 1/0.94 - 1/1 - 1/1.26 - 1/1.33 - 1/1.51 - 1/1.61 - 1/1.69 - 1/2.02 - 1/2.42
Distance Between Input-Output	270 mm / 10.630"	105 mm / 4.133"	-	220 mm / 8.66"
Required Oil	3,5 lt / 3,7 qt / 118 oz	1 lt / 1,05 qt / 34 oz	1 lt / 1,05 qt / 33 oz	2,25 lt / 2,38 qt / 76 oz

www.celiksana.com

## Sandwich PTO

CSW.100 / CSWH.103 / CSW.104 / CSW.109

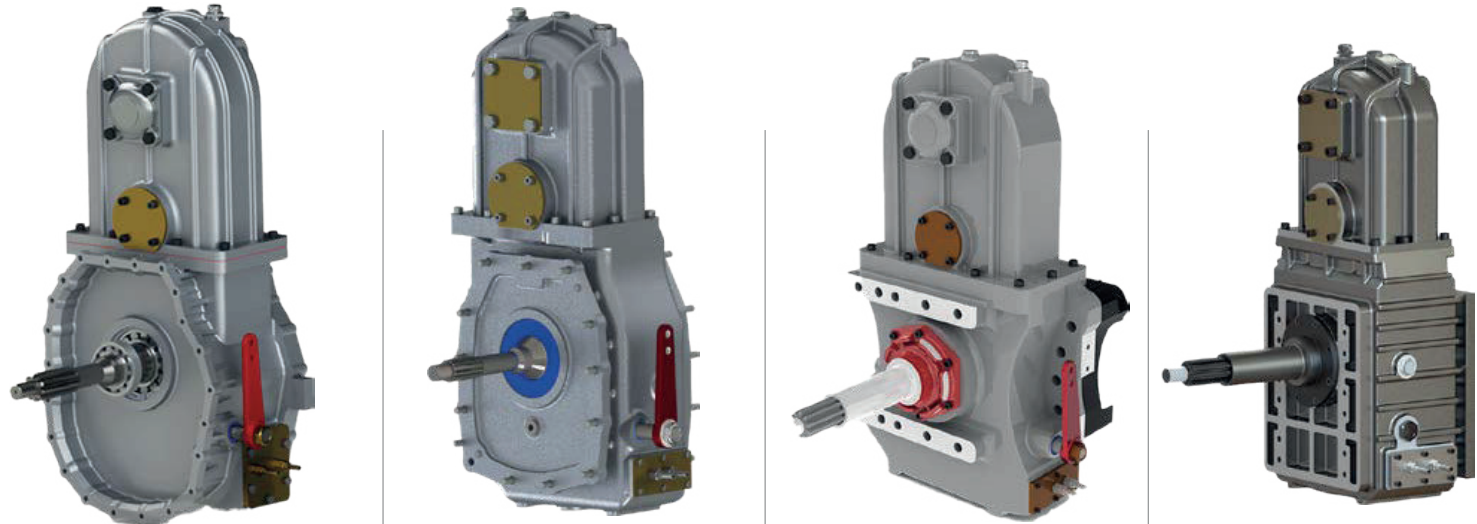

### CSW.100

**Product Features**  
 Body Material is Compatible with Main Transmission  
 Main Transmission Type : MZW 6P  
 Pump&Roll Feature  
 Self-Cooling System  
 Control Type: Pneumatic&Mechanic  
 Sense of rotation: Same as input  
 Mounting Type: Between Main Transmission and Flywheel Cover  
 Weight: 70 kg / 154 lb  
 2 Years Guarantee  
 10 Years Spare Part Warranty

**Options**  
 Engage/Disengage Sensor  
 Second PTO Output

**Applications**  
 Water Truck  
 Fire Fighting Truck  
 Vacuum Truck  
 Water Jetting Truck  
 Road Maintenance Vehicle  
 Mixer Truck

### CSW.103

**Product Features**  
 Body Material is Compatible with Main Transmission  
 Main Transmission Type: MYST/MOY 9F  
 Pump&Roll Feature  
 Self-Cooling System  
 Control Type: Pneumatic&Mechanic  
 Mounting Type: Between Main Transmission and Flywheel Cover  
 Weight: 65 kg / 144 lb  
 2 Years Guarantee  
 10 Years Spare Part Back Up

**Options**  
 Engage/Disengage Sensor  
 Second PTO Output

**Applications**  
 Water Truck  
 Fire Fighting Truck  
 Vacuum Truck  
 Water Jetting Truck  
 Road Maintenance Vehicle

### CSW.104

**Product Features**  
 Body Material is Compatible with Main Transmission  
 Main Transmission Type: ZF9S - 1115 TO  
 Pump&Roll Feature  
 Self-Cooling System  
 Control Type: Pneumatic&Mechanic  
 Sense of rotation: Same as Input  
 Mounting Type: Between Main Transmission and Flywheel Cover  
 Weight: 103 kg / 227 lb  
 2 Years Guarantee  
 10 Years Spare Part Back Up

**Options**  
 Engage/Disengage Sensor  
 Second PTO Output

**Applications**  
 Water Truck  
 Fire Fighting Truck  
 Vacuum Truck  
 Water Jetting Truck  
 Road Maintenance Vehicle  
 Mixer Truck

### CSW.109

**Product Features**  
 Body Material is Compatible with Main Transmission  
 Main Transmission Type : ES 11109 LH  
 Pump&Roll Feature  
 Self-Cooling System  
 Control Type: Pneumatic&Mechanic  
 Mounting Type: Between Main Transmission and Flywheel Cover  
 Weight: 80 kg / 177 lb  
 2 Years Guarantee  
 10 Years Spare Part Back Up

**Options**  
 Engage/Disengage Sensor  
 Second PTO Output

**Applications**  
 Water Truck  
 Fire Fighting Truck  
 Vacuum Truck  
 Water Jetting Truck  
 Road Maintenance Vehicle

## PTO SERIES

### Split Shaft PTO

CSS.400 / CSS.801

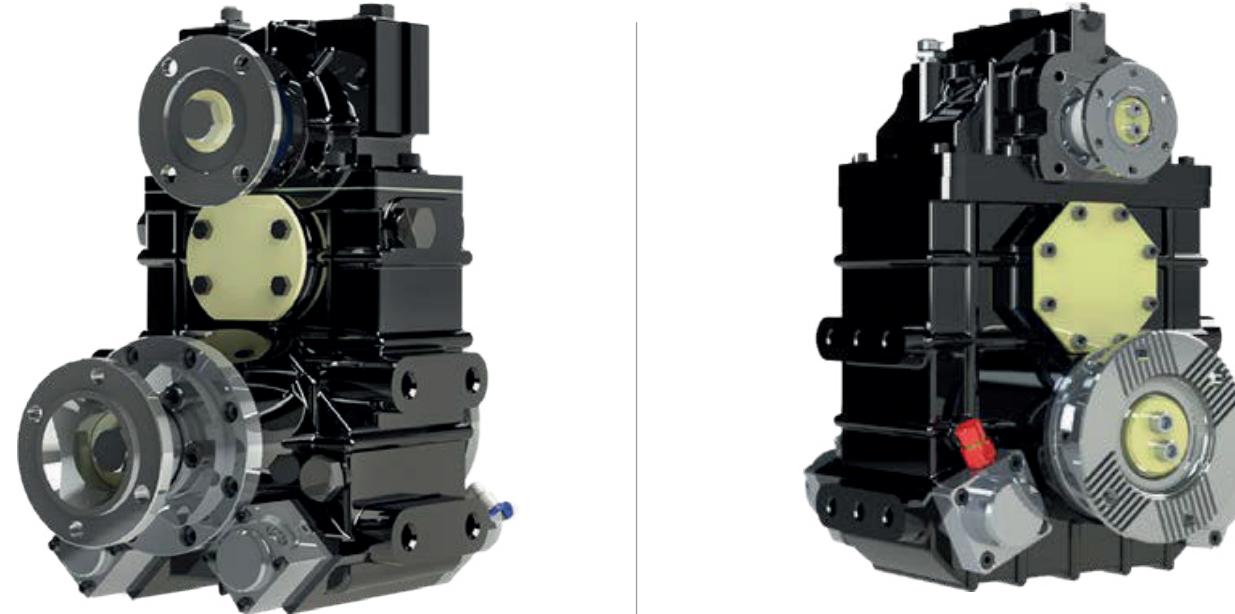

### CSS.400

**Product Features**  
 3-Stage Vertical Split Shaft PTO  
 Pump&Roll Feature  
 Control Type: Pneumatic&Mechanic  
 Mounting Type: Split Shaft  
 Sense of Rotation: Same as Input  
 Weight: 60 kg / 132 lb  
 2 Years Guarantee  
 10 Years Spare Part Back Up

**Options**  
 RPM Counter  
 Engage/Disengage Sensor  
 Drum Brake  
 Second PTO Output  
 Cooling System

**Applications**  
 Fire Fighting Truck  
 Fire Jeep  
 Water Truck

### CSS.801

**Product Features**  
 3-Stage Vertical Split Shaft PTO  
 Pump&Roll Feature  
 Control Type: Pneumatic&Mechanic  
 Mounting Type: Split Shaft  
 Sense of Rotation: Same as Input  
 Weight: 128 kg / 282 lb  
 2 Years Guarantee  
 10 Years Spare Part Back Up

**Options**  
 RPM Counter  
 Engage/Disengage Sensor  
 Drum Brake  
 Second PTO Output  
 Cooling System

**Applications**  
 Fire Fighting Truck  
 Water Truck

### Split Shaft PTO

CSS.2002 / CSS.2005

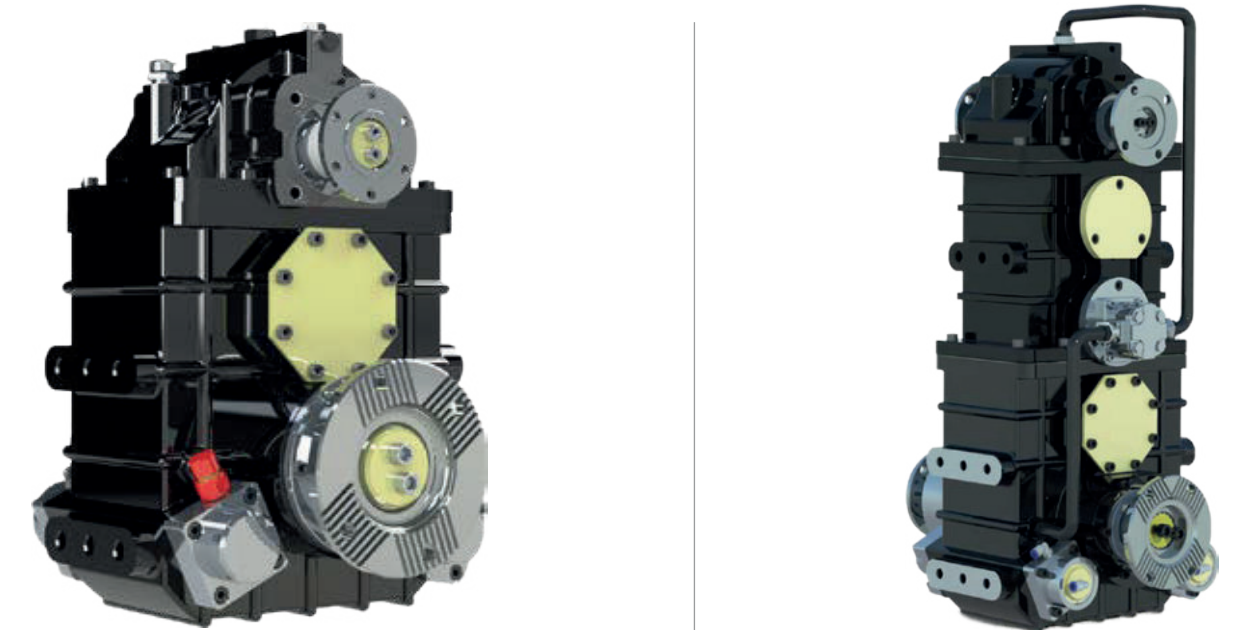

### CSS.2002

**Product Features**  
 3-Stage Vertical Split Shaft PTO  
 Pump&Roll Feature  
 Control Type: Pneumatic&Mechanic  
 Mounting Type: Split Shaft  
 Sense of Rotation: Same as Input  
 Weight: 135 kg / 297 lb  
 2 Years Guarantee  
 10 Years Spare Part Back Up

**Options**  
 RPM Counter  
 Engage/Disengage Sensor  
 Second PTO Output  
 Cooling System

**Applications**  
 Fire Fighting Truck  
 Water Truck

### CSS.2005

**Product Features**  
 5-Stage Vertical Split Shaft PTO  
 Pump&Roll Feature  
 Built-on Lubrication System  
 Control Type: Pneumatic&Mechanic  
 Mounting Type: Split Shaft  
 Sense of Rotation: Same as Input  
 Weight: 115 kg / 253 lb  
 2 Years Guarantee  
 10 Years Spare Part Back Up

**Options**  
 RPM Counter  
 Engage/Disengage Sensor  
 Second PTO Output  
 Cooling System

**Applications**  
 Fire Fighting Truck  
 Water Truck

Tech Specification	CSW.100	CSW.103	CSW.104	CSW.109
Max. Torque on Main Drive	2196 Nm / 224 kgm / 1620 lb-ft	1910 Nm / 195 kgm / 1409 lb-ft	4300 Nm / 438 kgm / 3172 lb-ft	438 kgm / 3168 lb-ft
Max. Power at PTO Output	124 kW / 166 HP	124 kW / 169 HP	159 kW / 213 HP	124 kW / 166 HP
Max. RPM	3500	3000	3500	3000
Available Internal Ratios	1/1.4, 1/1.5, 1/1.6, 1/1.7, 1/1.8, 1/2.2	1/1, 1/1.2, 1/1.4, 1/2.2	1/1.5, 1/2.2	1/1, 1/1.2, 1/1.4, 1/1.5, 1/2.2
Required Oil	6,5 lt / 6.7 qt / 220 oz	6,5 lt	6,5 lt / 6.7 qt / 220 oz	6,5 lt / 6.7 qt / 220 oz

Tech Specification	CSW.100	CSS.801
Max. Torque	430 kgm / 4216 Nm / 3110 lb-ft	800 kgm / 7845 Nm / 5786 lbs-ft
Max. Power at PTO Output	85 kW / 113 HP	135 kW / 180 HP
Available Internal Ratios	1/1.5 - 1/1.8	1/1-1/1.2-1/1.4-1/1.6-1/1.84-1/2.25
Required Oil	1.5 lt / 1.6 qt / 51 oz	3.5 lt / 3.7 qt / 118 oz

Tech Specification	CSS.2002	CSS.2005
Max. Torque	2100 kgm / 20593 Nm / 15190 lb-ft	2100 kgm / 20593 Nm / 15188 lb-ft
Max PTO Output Power	185 kW / 248 HP	185 kW / 248 HP
Available Internal Ratios	1/1, 1/1.4, 1/1.6, 1/1.84, 1/2.25	1/1.4 - 1/1.2 - 1/1.6 - 1/1.84 - 1/2.25
Required Oil	15 lt / 5.3 qt / 169 oz	6 lt / 6.3 qt / 202 oz